

25 August 2015

Chapter of the Year

UK Chapter – AOC Chapter of the Year. The UK Chapter has been recognized as Chapter of the Year in the large Chapter Category by the AOC. We share the honour with the Capitol Club (DC) and Dixie Crow (Georgia) Chapters. Thanks are due to all of the BOD and you, the UK Chapter members, who made this possible, throughout 2014 and 2015. We are off to a great start in July 2015 for the next year. If you or your company or establishment hosts visits or give external lectures and you extol the benefits of EW and the AOC and encourage new Chapter members please let us know. Media is available to help you including the UK Chapter flyer and BOD members will be available to help if possible and/or necessary.

DSEI 15-18 September ExCel London – Volunteers Needed. The Chapter have once again been invited to host an AOC stand during DSEI. Volunteers are needed to man the stand over the 4 days of the show and will each receive an "Exhibitor" badge which allows early and easier access. Apart from helping the Chapter out, hopefully recruiting new members and explaining the role of EW, the AOC and the UK Chapter, volunteers have access to all that DESI has to offer as the largest defence and security exhibition in the world. If you are willing to volunteer please email me at jonclif@aol.com and I will make the arrangements.

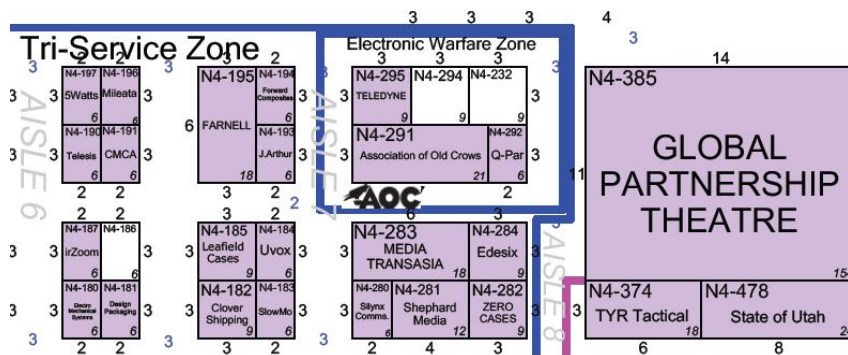

Visit to Farnborough – Air Platform Protection. The 16 Chapter members who attended the NATO Secret visit to Farnborough on 17th July were delighted by what they heard and saw. To be actually able to watch a major Air Platform Protection (AAP) trial in the remarkable Defence Missile Evaluation Centre as it neared its conclusion is probably unique and to be able to talk to the participants in the control room as it unfolded was incredible. While most of our members present had a background, mostly a highly technical and long-standing and renowned one, in APP, those from other areas of EW in the UK were perhaps the most enthralled. I guess this demonstrates the value of such events to our entire membership and I was pleased to see the amount of networking that went on. Many thanks go to Mark Elson MBE who offered the visit, and to Dr Sue Robertson, who arranged it. Dr Bob Andrews MBE, AOC International Region 1 Director, took time out from the trial to join us and between all of us we promoted the benefit of joining the AOC to all the international participants.



Chapter President John Clifford presented a UK Chapter Plaque for Excellence to Mark Elson MBE NAFAG AG3 SG2 Chairman.

Visit to Vulcan XH558 – A Date for Your Diary We have arranged a visit to see Vulcan XH558 in her original cold war hanger at Robin Hood Airport (formerly RAF Finningley), Doncaster, on Thursday 29 October, starting at

11:00. The Chapter will subsidise the visit, which will also include a small buffet lunch and time to explore the aircraft and hanger, at a cost of £10 to you. There will also be a talk on the EW fit of the Vulcan from Julian Grenfell (who was AEO leader when I flew with 101 Sqn, back in the day) and Phil Davies will provide an insight into his experience of flying XH558 as AEO over the past 7 years, members of the Defence Electronics History Society will also hopefully join us. It cannot fail to be a memorable day – in the presence of XH588 and some of the aircrew and ground crew who maintain her in her last year flying. There is a registration form and more information at the end of the newsletter.

To see where XH558 is due to fly near you for the last chance ever to see this amazing aircraft in flight check out <http://www.vulcantothesky.org/appearances.html> where you can also see much more about the “Vulcan to the Sky” charity, the visit opportunities and how to support them.

New Articles from Chapter Members I am delighted that John “Jacey” Wise MBE has found the time to write another great article, this time on “Radar Technology News” which is attached to this newsletter. In addition, Julian Grenfell has written an excellent paper, the first of a series, on a brief History of EO/IR (attached). All of the authors would no doubt appreciate any feedback, (as would I, your long-suffering author of these newsletters) – if you are moved to respond please send your comments to me at jonclif@aol.com and I will distribute them to the appropriate person. Additions, corrections and comments will all be appreciated, as will any criticism, provided it is sent on the back of a signed, but otherwise blank, cheque – only joking!

AOC Conferences Further afield, I have lobbied the US side of the AOC to hold more events that are open to everyone, rather than simply making them US Only. There will be an inaugural 5-Eyes conference on Cyber Electromagnetic Activity (CEMA), 6-8th October 2015, at Aberdeen Proving Ground, Maryland. More details can be found here: <http://www.crows.org/event/192-aoc-conferences/2015/10/06/34-cyber-electromagnetic-activity-2015.html>

Finally That’s all folks. I’ve listed a few dates below, where you might consider joining us and the wider AOC community in 2015. Remember, the UK Chapter is all about you, so please stay engaged and let the Board know what you want. Feedback is always welcome.



John Clifford OBE
UK Chapter President

SOME DATES FOR YOUR 2015 DIARY

DSEI AOC EW Pavilion/Stand 15-18 September 2015, Royal Victoria Dock, London.

Visit to RN Type 45 Destroyer, Portsmouth TBD 2015

Visit to VTST Vulcan XH 558 Robin Hood Airport, Doncaster, Thursday 29 Oct 2015,

RN EW Branch Reunion Saturday 17 October 2015, GIs Association Whale Island, Portsmouth. Visit <http://navygollies.com/2015.php> for all details. The Association has once again invited UK Chapter members to attend.

AOC 52nd Symposium 1 - 3 December 2015, **New Venue** Marriott Marquis DC and Convention Center, Washington, DC

UK Chapter Christmas Dinner 11 Dec 2015, RAF Club, Awards Dinner, Black-tie preferred.

AOC EW Europe 2016 10-12 May 2016, Ahoy Conference Centre, Rotterdam, Netherlands.

Check out our website at www.ukaoc.org

VISIT TO VULCAN XH558

Thursday 29th October 2015

Your Board is very pleased to announce that a visit to Vulcan XH558 has been arranged for AOC members and members of the Defence Electronics History Society. Owned and operated by Vulcan to the Sky Trust, XH558 is the only remaining airworthy example of the Vulcan. Sadly by the time we visit in October it will have made its last flight. The visit will commence at 11:00 and will include a tour of the aircraft with the opportunity to view the increasing number of historical Vulcan items and personal recollections on display around the hangar.



We shall also have the privilege of a presentation by chapter member Julian Grenfell with his experience of the EW fit of the aircraft. Phil Davies will also brief about flying the Vulcan as AEO over the past 7 years.

VISIT LOCATION

XH558 is based in hangar 3 at Robin Hood Airport, Doncaster Sheffield

VISIT COST

The visit will be subsidised by UK AOC chapter funds but there will be a charge of £10 per person (to include a buffet lunch), which will be collected on the day.

Members wishing to attend should send an email to Sue Robertson (sue@tpl.co.uk) as soon as possible. Numbers are limited so please act sooner rather than later and risk disappointment.

Please include the following information in your message:

Full Name:

AOC Membership No:

Mobile No:

Age range (under/over 65):

